



**N-channel 100V, 15A, TO-252 Power MOSFET 功率場效應管**

■ **Features 特點**

Low Reverse Transfer Capacitance 低反向傳輸能力

Fast Switching Speed 快的開關速度

Low Gate Charge 低電荷密度

$R_{DS(ON)Type95m\Omega@VGS=10V}$

$R_{DS(ON)Type100m\Omega@VGS=4.5V}$

■ **Applications 應用**

Uninterruptible Power Supply(UPS)不間斷電源

Inverter System 轉換系統

■ **Internal Schematic Diagram 內部結構**

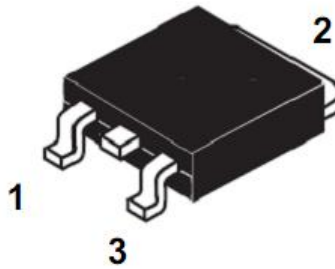
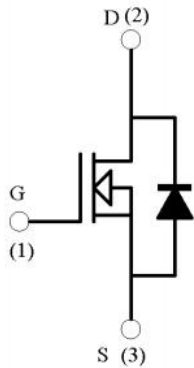

**TO-252**

■ **Absolute Maximum Ratings 最大額定值**

Characteristic 特性參數	Symbol 符號	Rat 額定值	Unit 單位
Drain-Source Voltage 漏極-源極電壓	$BV_{DSS}$	100	V
Gate- Source Voltage 柵極-源極電壓	$V_{GS}$	$\pm 20$	V
Drain Current (continuous)漏極電流-連續	$I_D$ (at $TC = 25^\circ C$ )	15	A
Drain Current (pulsed)漏極電流-脈沖	$I_{DM}$	60	A
Total Device Dissipation 總耗散功率	$P_{TOT}$ (at $TC = 25^\circ C$ )	55	W
Thermal Resistance Junction to Case 熱阻	$R_{\theta JC}$	2.72	$^\circ C/W$
Junction/Storage Temperature 結溫/儲存溫度	$T_J, T_{stg}$	-55~175	$^\circ C$

■ Electrical Characteristics 電特性

( $T_A=25^{\circ}\text{C}$  unless otherwise noted 如無特殊說明，溫度為  $25^{\circ}\text{C}$ )

Characteristic 特性參數	Symbol 符號	Min 最小值	Typ 典型值	Max 最大值	Unit 單位
Drain-Source Breakdown Voltage 漏極-源極擊穿電壓( $I_D=250\mu\text{A}, V_{GS}=0\text{V}$ )	$BV_{DSS}$	100	—	—	V
Gate Threshold Voltage 柵極開啓電壓( $I_D=250\mu\text{A}, V_{GS}=V_{DS}$ )	$V_{GS(th)}$	1	1.6	3	V
Zero Gate Voltage Drain Current 零柵壓漏極電流( $V_{GS}=0\text{V}, V_{DS}=100\text{V}$ )	$I_{DSS}$	—	—	1	$\mu\text{A}$
Gate Body Leakage 柵極漏電流( $V_{GS}=\pm 20\text{V}, V_{DS}=0\text{V}$ )	$I_{GSS}$	—	—	$\pm 100$	nA
Static Drain-Source On-State Resistance 静态漏源導通電阻( $I_D=10\text{A}, V_{GS}=10\text{V}$ ) ( $I_D=5\text{A}, V_{GS}=4.5\text{V}$ )	$R_{DS(ON)}$	—	95 100	110 130	$\text{m}\Omega$
Diode Forward Voltage Drop 內附二極管正向壓降( $I_{SD}=10\text{A}, V_{GS}=0\text{V}$ )	$V_{SD}$	—	—	1.2	V
Input Capacitance 輸入電容 ( $V_{GS}=0\text{V}, V_{DS}=50\text{V}, f=1\text{MHz}$ )	$C_{ISS}$	—	632	—	pF
Common Source Output Capacitance 共源輸出電容( $V_{GS}=0\text{V}, V_{DS}=50\text{V}, f=1\text{MHz}$ )	$C_{OSS}$	—	37	—	pF
Reverse Transfer Capacitance 反向傳輸電容 ( $V_{GS}=0\text{V}, V_{DS}=50\text{V}, f=1\text{MHz}$ )	$C_{RSS}$	—	21	—	pF
Total Gate Charge 總柵極電荷密度 ( $V_{DS}=80\text{V}, I_D=10\text{A}, V_{GS}=10\text{V}$ )	$Q_g$	—	19.2	—	nC
Gate Source Charge 柵源電荷密度 ( $V_{DS}=80\text{V}, I_D=10\text{A}, V_{GS}=10\text{V}$ )	$Q_{gs}$	—	3.4	—	nC
Gate Drain Charge 柵漏電荷密度 ( $V_{DS}=80\text{V}, I_D=10\text{A}, V_{GS}=10\text{V}$ )	$Q_{gd}$	—	6.1	—	nC
Turn-On Delay Time 開啓延遲時間 ( $V_{DS}=50\text{V}, I_D=10\text{A}, R_{GEN}=6\Omega, V_{GS}=10\text{V}$ )	$t_{d(on)}$	—	12.6	—	ns
Turn-On Rise Time 開啓上升時間 ( $V_{DS}=50\text{V}, I_D=10\text{A}, R_{GEN}=6\Omega, V_{GS}=10\text{V}$ )	$t_r$	—	6	—	ns
Turn-Off Delay Time 關斷延遲時間 ( $V_{DS}=50\text{V}, I_D=10\text{A}, R_{GEN}=6\Omega, V_{GS}=10\text{V}$ )	$t_{d(off)}$	—	32.5	—	ns
Turn-On Fall Time 開啓下降時間 ( $V_{DS}=50\text{V}, I_D=10\text{A}, R_{GEN}=6\Omega, V_{GS}=10\text{V}$ )	$t_f$	—	4.3	—	ns



■ Typical Performance Characteristics 典型功能特性

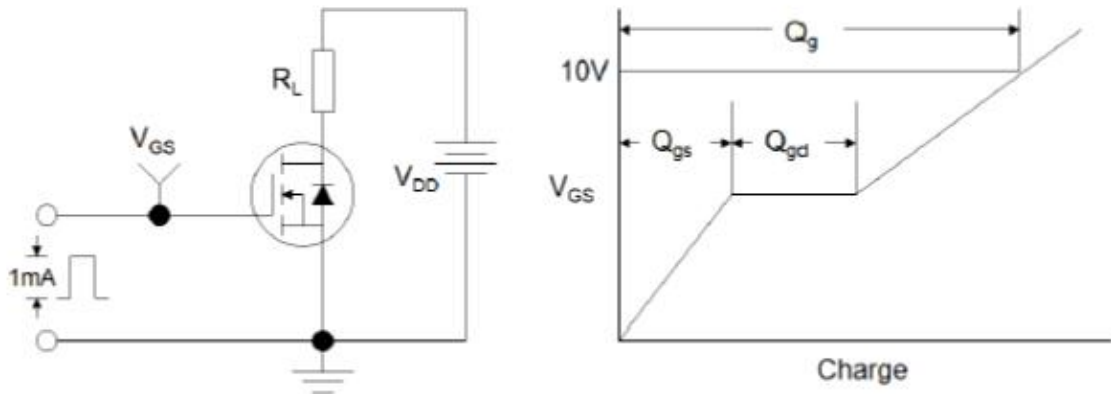

Figure1:Gate Charge Test Circuit & Waveform

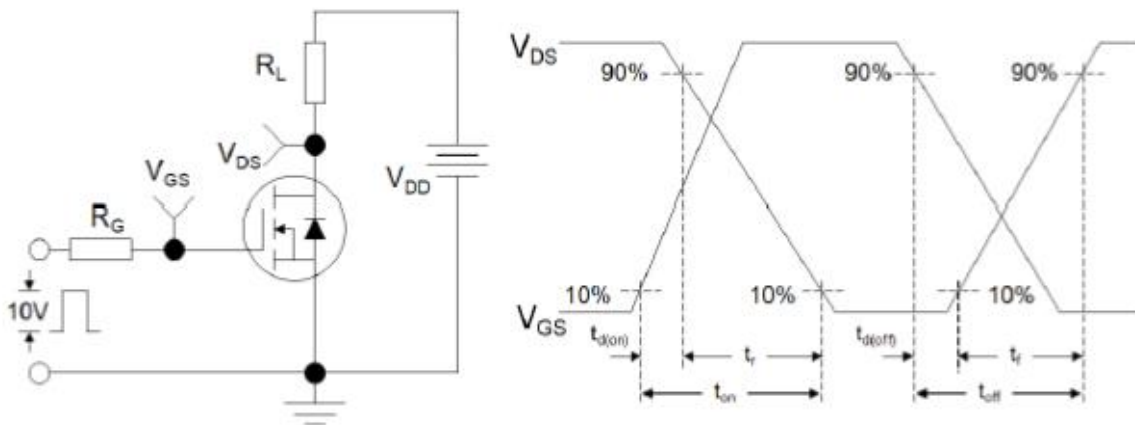

Figure 2: Resistive Switching Test Circuit & Waveforms

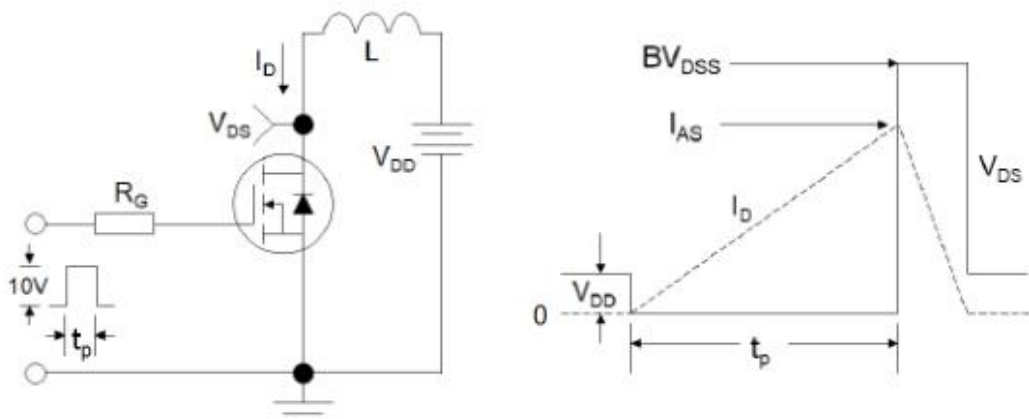

Figure 3:Unclamped Inductive Switching Test Circuit & Waveforms

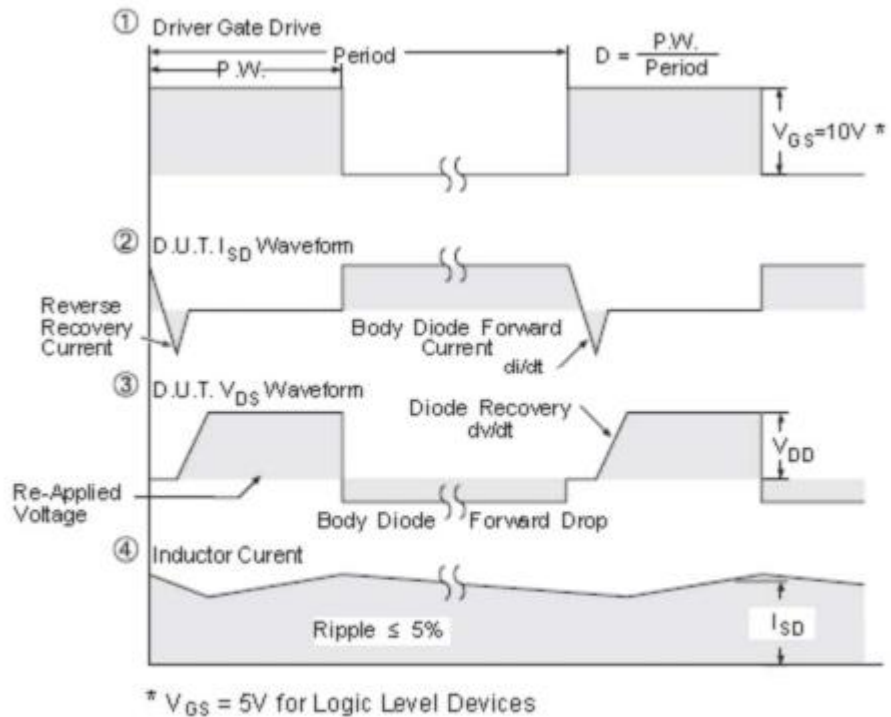
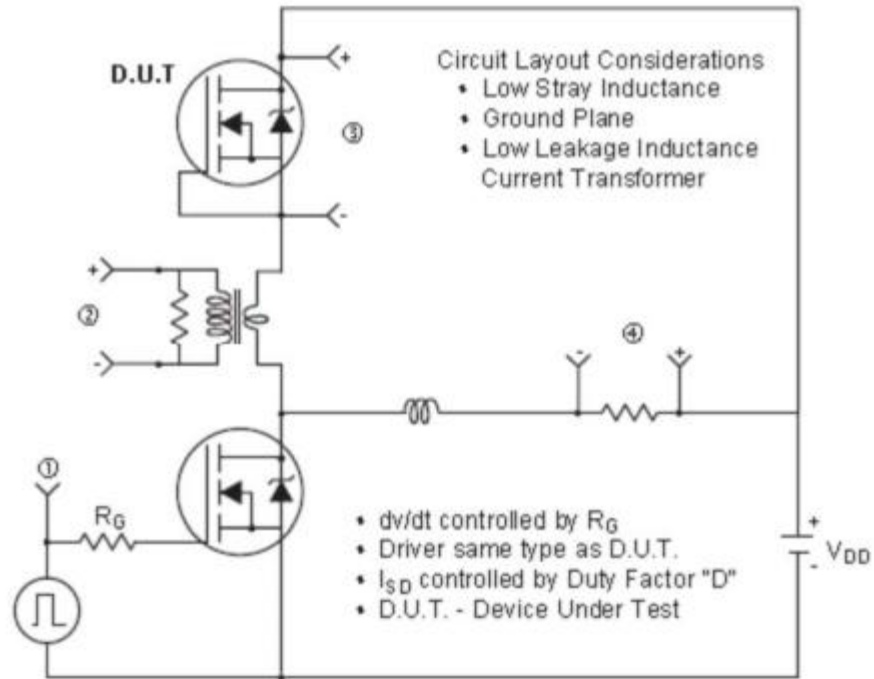
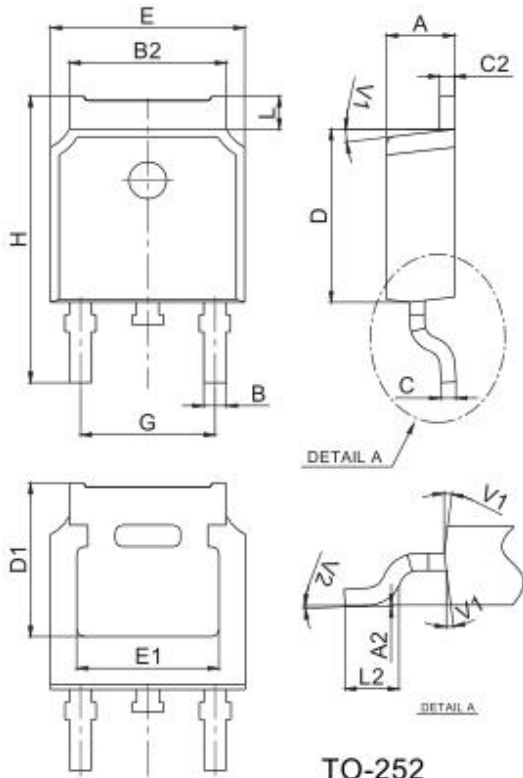

Figure 4: Peak Diode Recovery  $dv/dt$  Test Circuit & Waveforms (For N-channel)



■DIMENSION 外形封裝尺寸



Ref.	Dimensions					
	Millimeters			Inches		
	Min.	Typ.	Max.	Min.	Typ.	Max.
A	2.10		2.50	0.083		0.098
A2	0		0.10	0		0.004
B	0.66		0.86	0.026		0.034
B2	5.18		5.48	0.202		0.216
C	0.40		0.60	0.016		0.024
C2	0.44		0.58	0.017		0.023
D	5.90		6.30	0.232		0.248
D1	5.30REF			0.209REF		
E	6.40		6.80	0.252		0.268
E1	4.63			0.182		
G	4.47		4.67	0.176		0.184
H	9.50		10.70	0.374		0.421
L	1.09		1.21	0.043		0.048
L2	1.35		1.65	0.053		0.065
V1		7°			7°	
V2	0°		6°	0°		6°

Reel Spectification-TO-252

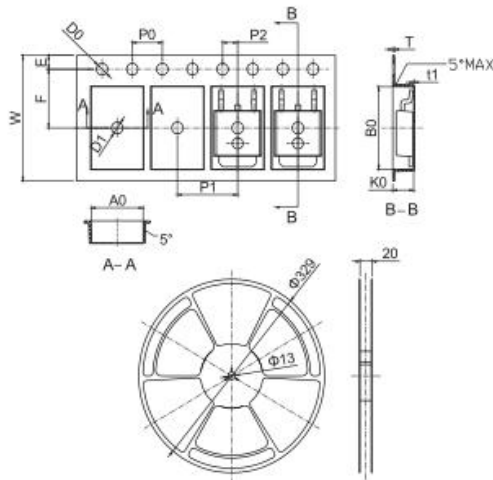

Ref.	Dimensions					
	Millimeters			Inches		
	Min.	Typ.	Max.	Min.	Typ.	Max.
W	15.90	16.00	16.10	0.626	0.630	0.634
E	1.65	1.75	1.85	0.065	0.069	0.073
F	7.40	7.50	7.60	0.291	0.295	0.299
D0	1.40	1.50	1.60	0.055	0.059	0.063
D1	1.40	1.50	1.60	0.055	0.059	0.063
P0	3.90	4.00	4.10	0.154	0.157	0.161
P1	7.90	8.00	8.10	0.311	0.315	0.319
P2	1.90	2.00	2.10	0.075	0.079	0.083
A0	6.85	6.90	7.00	0.270	0.271	0.276
B0	10.45	10.50	10.60	0.411	0.413	0.417
K0	2.68	2.78	2.88	0.105	0.109	0.113
T	0.24		0.27	0.009		0.011
t1	0.10			0.004		
10P0	39.80	40.00	40.20	1.567	1.575	1.583

OUTLINE	REEL (PCS)	PER CARTON (PCS)	TAPE & REEL
TAPING	2,500	25,000	13inch